

CPS PSA7MO

Transformer Station



Simple

- Prefabricated and Pre-tested, No Internal Cabling Needed Onsite
- Compact 20' HC Container Design for Easy Transportation and deployment.

Smart and Compatible

- Real-time Monitoring of Transformer, LV Panel and RMU
- High Precision Sensor of LV Electricity Parameters
- Remote Control of ACB and MV Circuit Breaker, fully compatible design with SCH350K-T-EU

Schematic Diagram

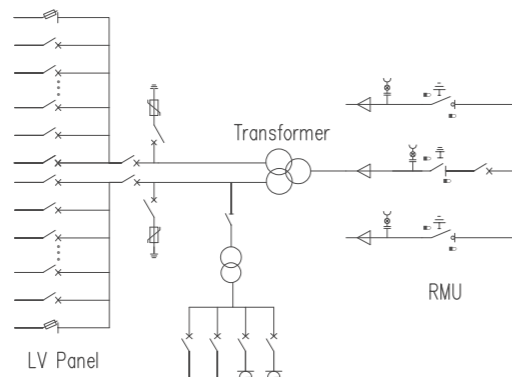

Efficient and Compliant

- EU compliance ,High Efficiency Transformer for Higher Yields, Lower Self-consumption for Higher Yields

Reliable

- Robust Design against Harsh Environments
- Optimal Cooling Design for High Availability and Easy O&M

Technical Specifications

Model name	CPS PSA7MO
Input	
Available Inverters	SCH350K-T-EU
Max. LV AC Inputs	20
AC Power ¹	7,000 kVA @40°C (Optional: 7000kVA@45°C)
Rated Input Voltage	800 V
LV Main Inputs	ACB (3,200 A / 800 V / 3P, 2 x 1 pcs), MCCB (320 A / 800 V / 3P, 2 x 10 pcs)
Output	
Rated Output Voltage	15 kV, 20 kV, 30 kV, 33 kV ²
Frequency	50 Hz
Transformer Type	Oil-immersed, Conservator Type
Transformer Cooling Type	ONAN
Transformer Tappings	± 2 x 2.5%
Transformer Oil Type	Mineral Oil (PCB Free)
Transformer Vector Group	Dy11-y11
Transformer Min. Peak Efficiency Index	In Accordance with EN 50588-1
RMU Type	SF ₆ Gas Insulated
RMU Transformer Protection Unit	MV Vacuum Circuit Breaker Unit
RMU Cable Incoming / Outgoing Unit	Direct Cable Unit or Cable Load Break Switch Unit
Auxiliary Transformer	Dry Type Transformer, 5 kVA, Dyn11, 0.8/0.4kV
Output Voltage of Auxiliary Transformer	400 / 230 Vac
Protection	
Transformer Monitoring & Protection	Oil Level, Oil Temperature, Oil Pressure and Buchholz
Protection Degree of MV & LV Room	IP 54
Internal Arcing Fault of RMU	20 kA 1s
MV Relay Protection	50/51, 50N/51N
LV Overvoltage Protection	Type II
Anti-rodent Protection	C4-H in accordance with ISO 12944
Features	
2 kVA/1h UPS	Optional ³
MV Surge Arrester for Transformer	Optional ³
IMD	Optional ³
General	
Dimensions (W x H x D)	6,058 x 2,896 x 2,438mm (20' HC Container)
Weight	< 22t
Operating Temperature Range	-25°C ~ 60°C ⁴ (-13°F ~ 140°F)
Relative Humidity	0% ~ 95%
Max. Operating Altitude	1,000m ⁵
MV-LV AC Connections	Prewired and Pretested, No Internal Cabling Onsite
LV & MV Room Cooling	Heat exchanger without Air-across for Higher Availability Preconfigured with PCOMM
Communication Interface	RS232, RS485, Ethernet, DI/DO, AI/AO
Communication Protocol	Modbus TCP, Modbus RTU, IEC 60870-5-103, IEC 60870-5-104
Applicable Standards	IEC 62271-202, IEC 50708-3, IEC 62271-200, IEC 61439-2
<small>1- More detailed AC power of transformer, please refer to the de-rating curve. 2- Rated output voltage from 15kV to 35kV, more available upon request 3- Extra expense needed for optional features which standard product doesn't contain, more options upon request. 4-When ambient temperature ≥55°C, awning shall be equipped on site by customer. 5- For higher operating altitude, please consult with Chint Power.</small>	