

QUICK INSTALLATION GUIDE

Single-phase Grid-tied PV String Inverter

CPS SCA7KTL-PSM/EU
CPS SCA8KTL-PSM/EU
CPS SCA10KTL-PSM/EU

Version: 0.0

Date: 13/01/23

SHANGHAI CHINT POWER SYSTEMS CO.,LTD

Office Site: www.chintpower.com

Customer Service Line: 021-37791222-866300

1 PACKAGE CONTENTS

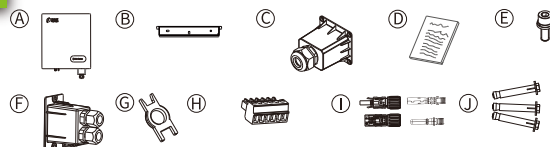

- A Inverter
- B Mounting bracket
- C AC output Connector
- D File package
- E Screw
- F RS485 Cover
- G Removal tool for DC connector
- H 6-Pin terminal
- I DC terminal connector group
- J Expansion screw group

2 INSTALLATION LOCATION

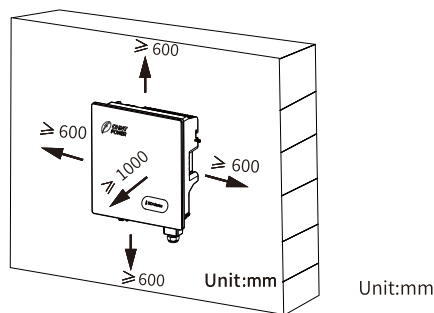
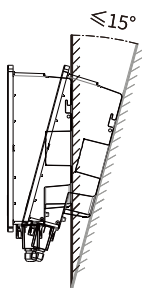
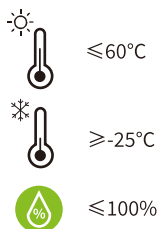

3 DIMENSIONS

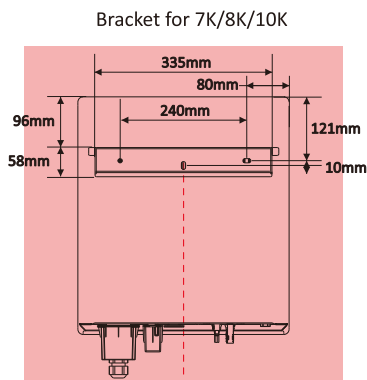
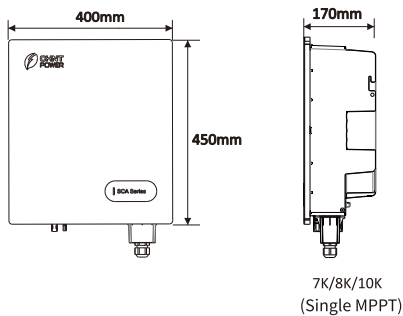

4 GROUNDING

- According to regulations, the secondary protection grounding can't replace the PE terminal connection of the AC cable. Ensure that both are grounded reliably.
- Ensure that inverter and all cables to be installed are completely powered off during whole installation and connection. Otherwise, fatal injury can occur due to the high voltage caused from AC and DC cables.

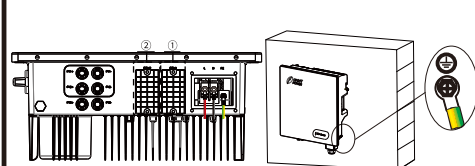

Items	Remark
Screw	M4 X 12mm; 1.2 N.m
OT Terminal	OT6-4
Yellow green lines	$S_{\text{Yellow green lines}} \geq S_{\text{PE line of AC cable}}$ S is the cross-sectional area.

Note: ① is for WiFi/GPRS communication
② is for RS485 communication (For RS485 cable connection, refer to user manual.)

5 INSTALLATION



- The walls must be fireproof and non-flammable materials, otherwise there is a fire risk.
- Before drilling holes, check whether there are electric power pipes or other pipes buried in the walls to avoid risks.

Note: The following steps are only illustrated by the type A bracket.

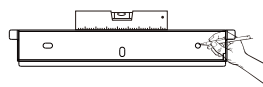

Set bracket horizontally.
Mark the holes position on the wall.

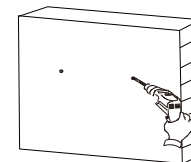

Ø: 10mm; Depth: 60mm

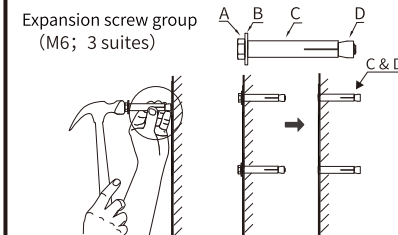

Install the expansion tubes.

1

2

3

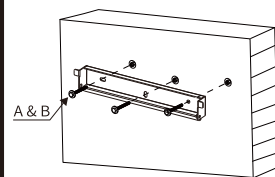

M6 Expansion screws; 2~2.5N.m

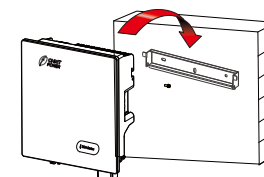

Install the inverter.

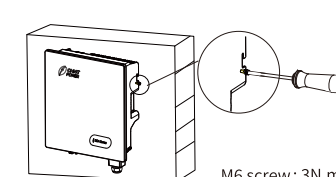

M6 screw; 3N.m
Tighten the screws at sides.

4

5

6

6 AC CONNECTION



- Before connecting the AC terminal, ensure that both the AC terminal and the DC terminal are powered off and the DC switch is OFF. Otherwise there is a risk of high voltage shock.

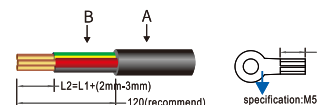

It is recommended to use outdoor dedicated cables with multiple copper cores.

No.	Name	Model	7K-10K
A	Wire outer diameter (mm)		14-20
B	Cross-sectional area (mm ²)	Range	8
		Recommended	8-14

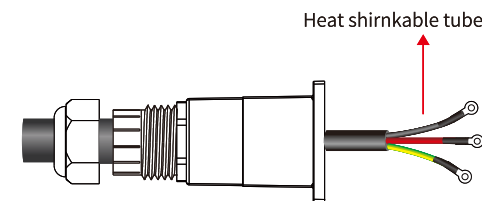

1 Wires making.

2 Wires threading and pressing.

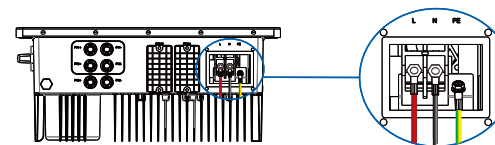

Screw Torque	
7K-10K	M5 1.5N.m

Lock the AC cable to the corresponding AC terminals.

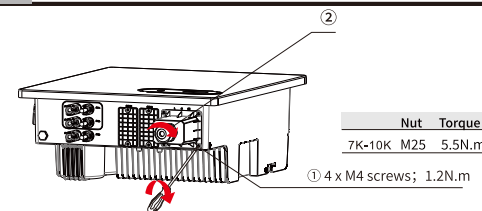

Nut	Torque
7K-10K M25	5.5N.m

① 4 x M4 screws; 1.2N.m

① Align the AC cover with the 4 holes and tighten it firmly with 4 x M4 screws.

② Fasten the nut (waterproof cap).

3

4

7 PV CONNECTION



1. Photovoltaic arrays exposed to sunlight will generate dangerous voltages!
2. Before connecting the DC terminal, ensure that both the AC terminal and the DC terminal are powered off and the DC SWITCH is OFF. Otherwise there is a risk of high voltage shock.

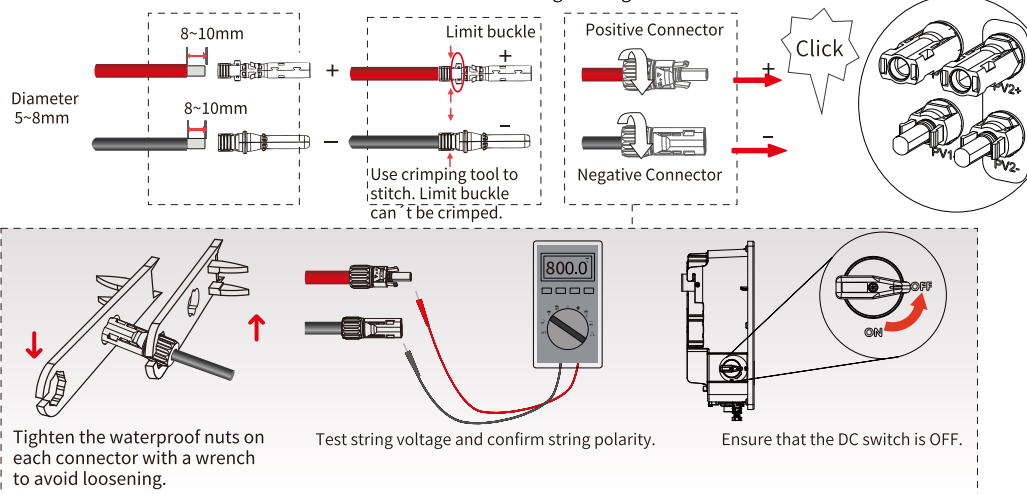

Note: DC cable should be dedicated PV cable (suggest using 4-6mm² PV1-F cable)

8 STARTUP / SHUTDOWN PROCEDURE

Inspection

No. Items

- 1 The inverter is firmly installed.
- 2 There is enough heat dissipation space, no external objects or parts left on the inverter.
- 3 It is convenient for operation and maintenance.
- 4 The wiring of the system is correct and firm.
- 5 Check whether the DC and AC connections are correct with a multimeter, and whether there is a short circuit, break, or wrong connection.
- 6 Check whether the waterproof nuts of each part are tightened.
- 7 The vacant port has been sealed.
- 8 All safety labels and warning labels on the inverter are complete and without occlusion or alteration.

After the inverter is powered off, the remaining electricity and heat may still cause electrical shock and body burns. If need to disconnect the inverter cables, please wait at least 10 minutes before touching these parts of inverter.

Startup Procedure

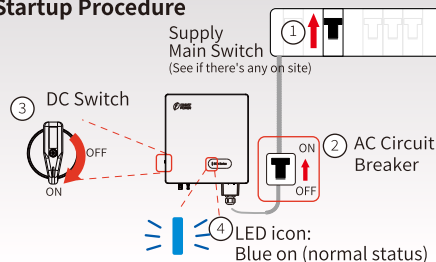

Shutdown Procedure

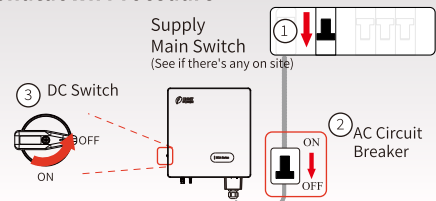

9 BLUETOOTH CONNECTION SETTING



NOTICE

After the inverter is installed and powered on, please use the APP (Chint Connect) to connect to the mobile phone Bluetooth to calibrate the time.

1. Scan the QR code to download "Chint Connect" APP:

Note: You need to grant all access rights in all pop-up windows when installing the APP or setting your phone.



2. Install WIFI module into the COM1 port of the inverter.
3. Power on the inverter.
4. Open the Bluetooth function on your own phone, then open the APP and operate as below.
 - 4-1. Touch "Smart Link" icon to enter smart link interface and then click "Next" button to enter the "Connect to the adapter" interface.
 - 4-2. Choose correct wireless network name (can be found on the WiFi module) from the Bluetooth List, the inverter will connect to WiFi dongle.
 - 4-3. Click "INV/ESI settings" button to enter the "Inverter Settings" page.
 - 4-4. Click "Initial" button to set grid code, then get back and click "RW Register" button to set register parameters or modbus address if necessary. Now you can click "Overview" button to see basic information.

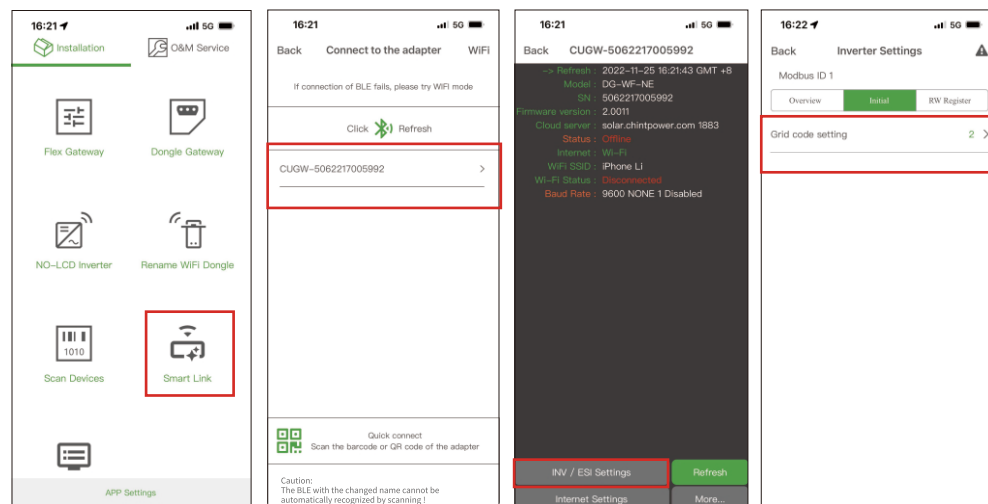

10 DISPLAY

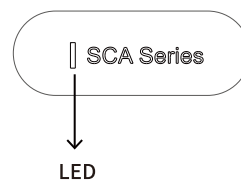

LED status	Explanation
Red/green/blue light up in turn	1. Inverter firmware updating 2. Initial status of power-on
Blue blinks slowly (1s/time)	Standby
Blue on	Normal status
Green on	Power limited status
Red blinks slowly (1s/time)	Output side fault
Red blinks fast (0.25s/time)	Input side fault
Red on	Inverter internal fault