

Single-phase Energy Storage Inverter

ECH3/3.6/4.6/5/6K-SML-EU Series

Quick Guide

Version: 1.0 Date: Apr, 2024 Doc. No.:9.0020.0652A0

Shanghai Chint Power Systems Co., Ltd.

Official Site: www.chintpower.com

Customer Service line: +86-21-37791222-866300

NOTICE: Before installation, please read the Quick Guide carefully. Failure to follow the instructions therein will invalidate the warranty!

1 Product Components and Dimensions

1.1 Product Components

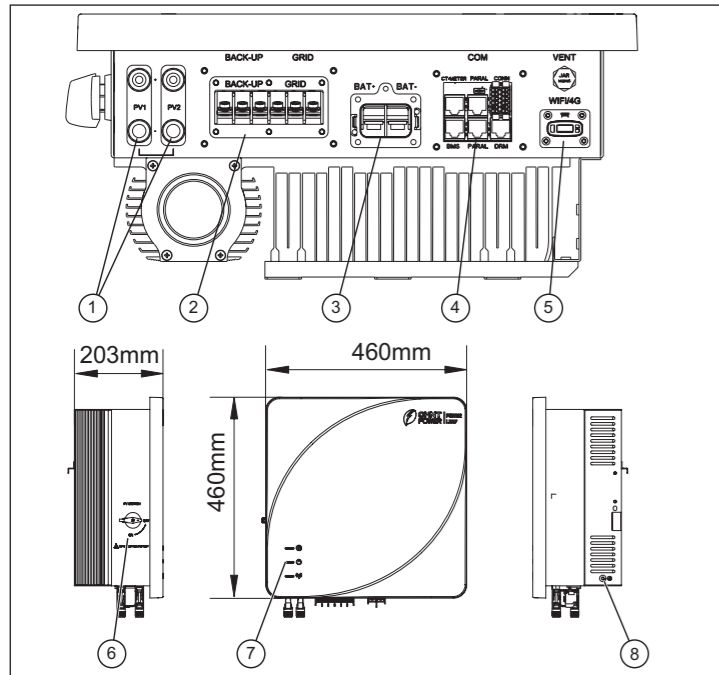

No.	Name	Function
1	PV DC input terminal	Connect DC cable
2	AC output terminals (BACK-UP and GRID)	Connect load cable and grid cable
3	BAT terminal	Connect battery cable
4	COM port	External communication
5	WIFI/4G port	Connect COM rod
6	DC-Switch	Power ON/OFF PV power supply
7	LED indicator	Indicate the product operation state
8	Protection earthing hole	Protective earthing

2 Installation

2.1 Scope of Delivery

Each inverter carton includes the following accessories:

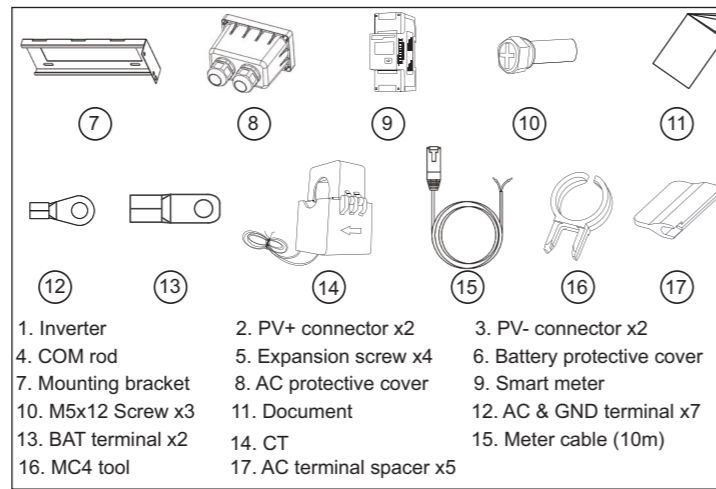
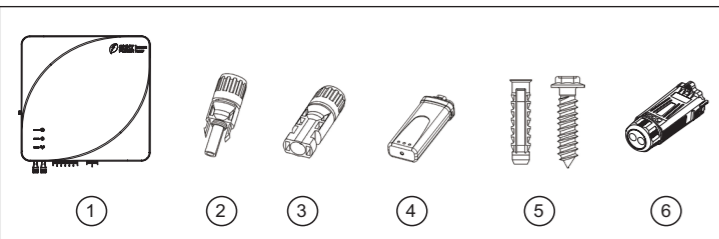

2.2 Installation Environment

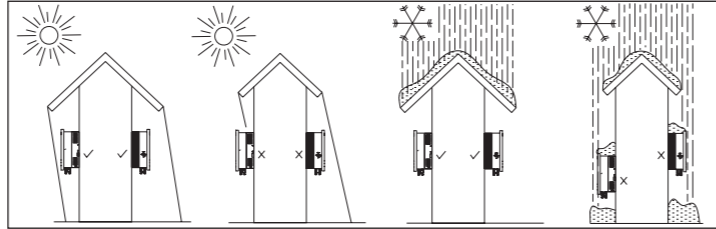

2.3 Installation Mode Requirements

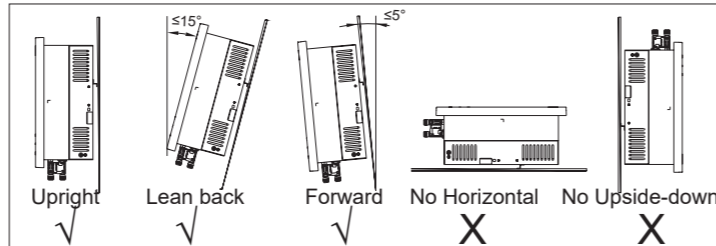

2.4 Installation Space Requirements

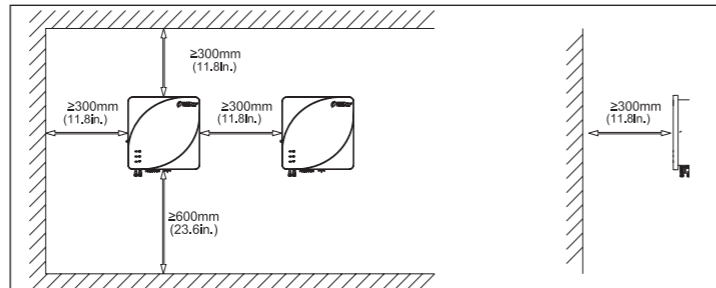

2.5 Inverter Installation

1. Place mounting bracket horizontally on wall and mark drilling holes with marker pen according to dimension requirements.

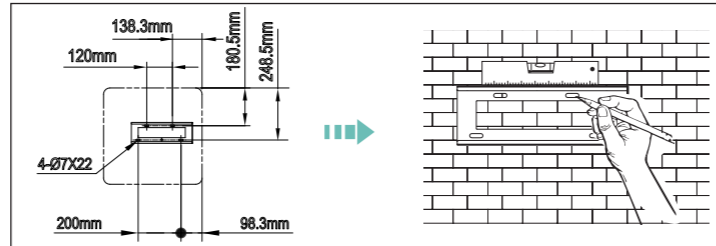

2. Use drill (Φ10 mm bit) to drill holes (70 mm deep). Use rubber hammer to knock in 4 expansion tubes. Tighten expansion screws to fix the mounting bracket. Torque: 12.5 N.m. Tool: PH2 screwdriver.

3. Hang inverter onto the mounting bracket.

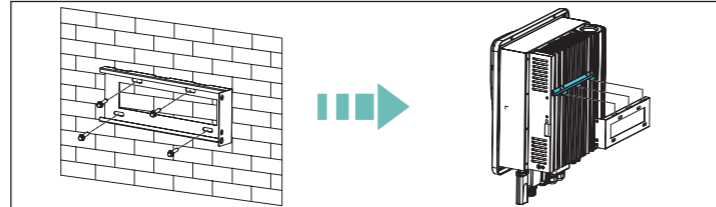

NOTICE Before installing inverter, ensure that supporting structure can support its weight (26 kg).

4. Tighten two M5x12 screws (1) to fix the mounting bracket and inverter. Tool: PH2 screwdriver, torque: 1.5-2 N.m. Finally, it is recommended to install an anti-theft lock (2).

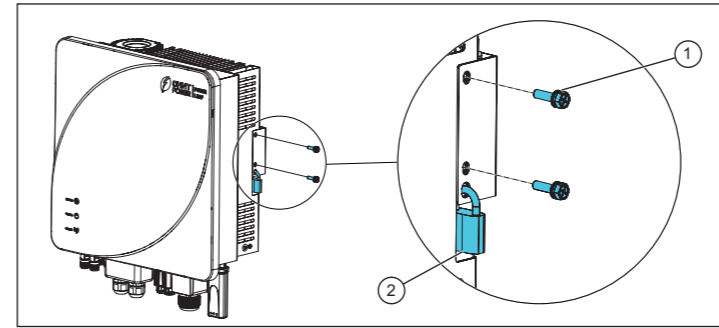

3 Electrical Connection



WARNING

Before electrical connection, ensure that AC terminal, DC terminal and battery terminal of the inverter are all de-energized. Otherwise, there is a risk of HV electric shock. All electrical operators must comply with local electrical installation standards and wear proper personal protective equipments.

3.1 Tools and torques

No.	Tools	Usage	Torque
1	Phillips screwdriver	AC wiring terminal	1.5-2 N.m
		Earthing terminal	1.5-2 N.m
		AC port protective cover	1.2-1.5 N.m
		COM port protective cover	1.2-1.5 N.m
		Battery wiring terminal	5-6 N.m
2	Diagonal pliers	Cut cables	-
3	Wire stripper	Strip cables	-
4	Crimping pliers	Crimp cables	-
5	Hot air gun	Seal heat shrink tube	-

3.2 Cable Specification

Please prepare the cables by yourself, the specification of the cables can refer to the table below:

Name	Cable Type	(Material of wire: copper) Section Area of Conductor	
		Range	Recommended value
AC-end Grid and BACK-UP	Multi-core outdoor special cable	8-12 mm ² 8-6 AWG	12 mm ² 6 AWG
PV DC end	General PV cable in the industry (model PV1-F)	4-6 mm ² 12-10 AWG	4 mm ² 12 AWG
Secondary protective earthing	Outdoor special cable (Color: yellow-green)	8-12 mm ² 8-6 AWG	12 mm ² 6 AWG
Battery DC end	Outdoor special cable	22-34 mm ² 4-2 AWG	22 mm ² 4 AWG

3.3 Secondary Protective Grounding Cable Connection



WARNING

The protective grounding of the housing cannot replace that of the AC output port. When wiring, ensure that both protective grounding cables are reliably connected. When there are multiple inverters, ensure the protective earthing equipotential connection of all inverter housings.

1. Remove an appropriate length of insulation layer from the ground wire.

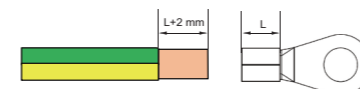

2. Insert the exposed wire core into the crimping area of the OT terminal, use crimping pliers to crimp the OT terminal. After crimping, wrap the wire crimping area with heat shrink tube and use hot air gun to seal the tubes.

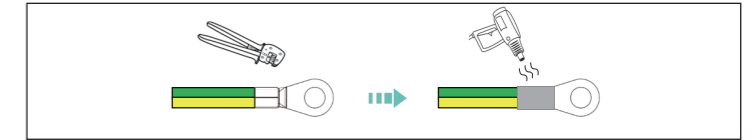

3. Tighten the M5x12 screw to fix the OT terminal of grounding cable. Torque: 1.5-2.0 N.m. (Note: To improve the corrosion resistance of terminals, it is recommended to apply silicone or paint on the outside of the grounding terminal after connection.)

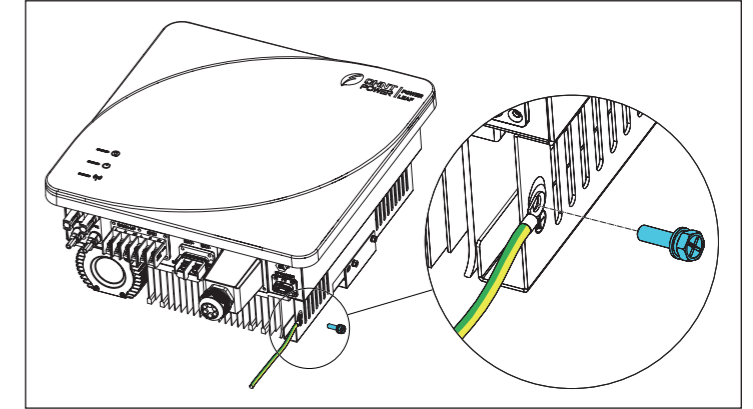

3.4 GRID and BACK-UP (Load) Cable Connection



WARNING

Never confuse load wiring ports and power grid wiring ports. Disconnect the grid-side switch and power off inverter at first, and then carry out wiring.

1. Screw off the nut (2) of the protective cover (1), put the GRID cable (3) through the nut.

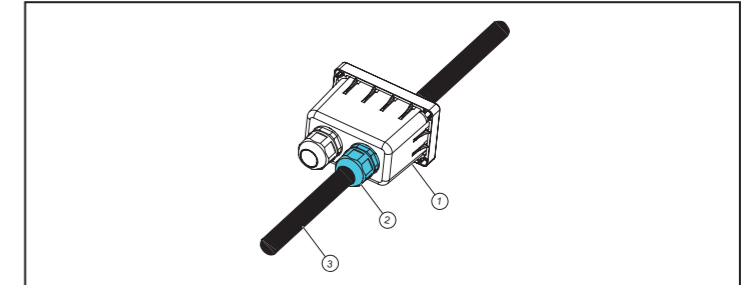

2. Crimp the OT terminals by referring to section 3.3.

3. Screw off the screws on the GRID AC port, connect the GRID cables to L, N and PE studs, and tighten the screws again.

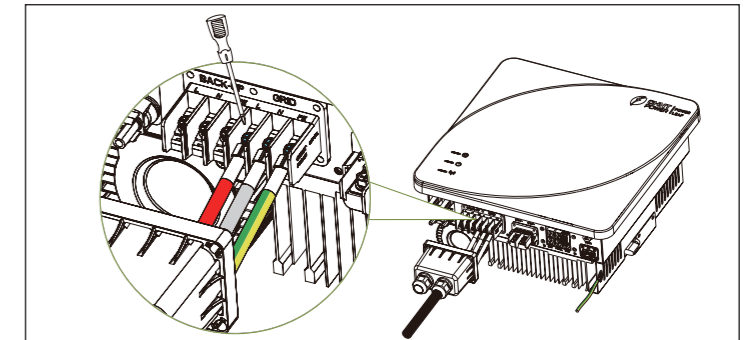

4. Connect the BACK-UP (Load) cable and insert the AC terminal spacers.

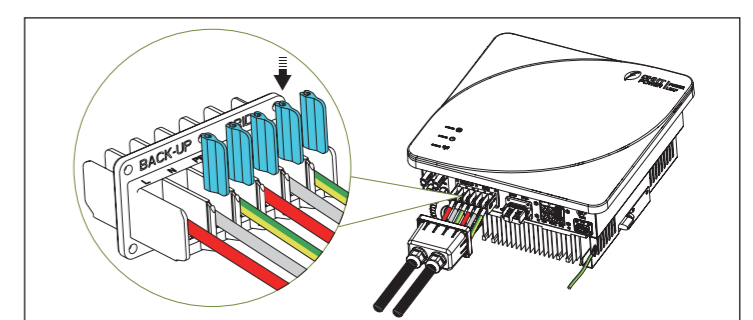

5. After finishing connecting the GRID cables (1) and BACK-UP cables (2), tighten the screws (5) to install the protective cover and tighten the two nuts (4) on the protective cover (3).

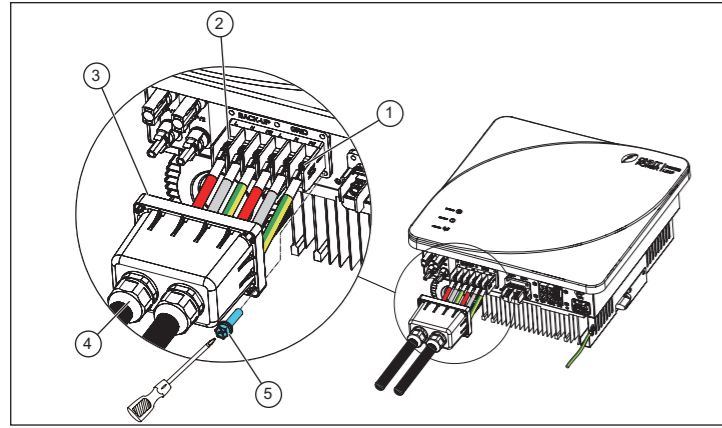

3.5 Battery Cable Connection

1. Disassemble the battery protective cover and thread the battery cables through the nut (1), sleeve (2), clamping ring (3) and cover (4).

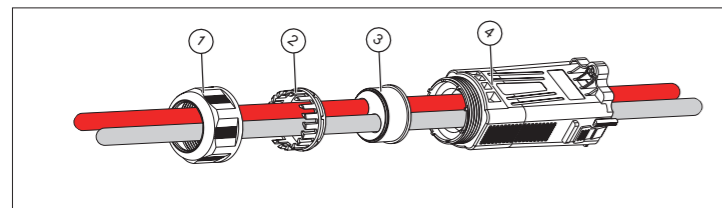

2. Crimp the battery cable and battery terminal by referring to section 3.3.
3. Screw off the two screws (1) on the battery terminal (BAT+ and BAT-). Position the BAT OT terminals onto wiring holes and re-tighten the screws (1) with phillips screwdriver.
4. Push the protective cover (2) towards the port until you hear a "click" sound and tighten the screw (3) of protective cover.

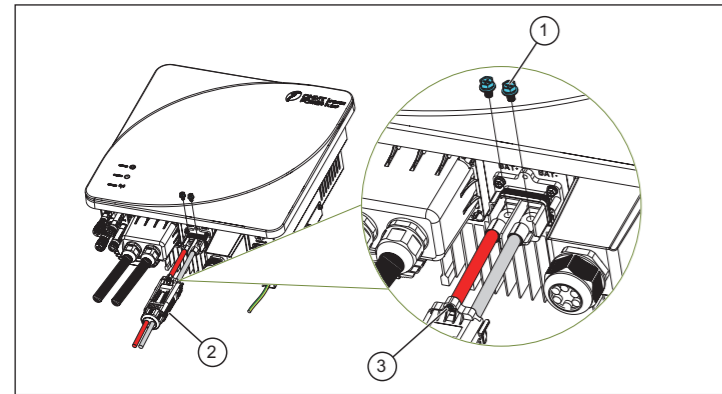

3.6 COM Rod Installation

Insert the COM rod in the accessories into the WIFI/4G port of the inverter until you hear a "click" sound.
Note: The indicators of COM rod shall face outward.

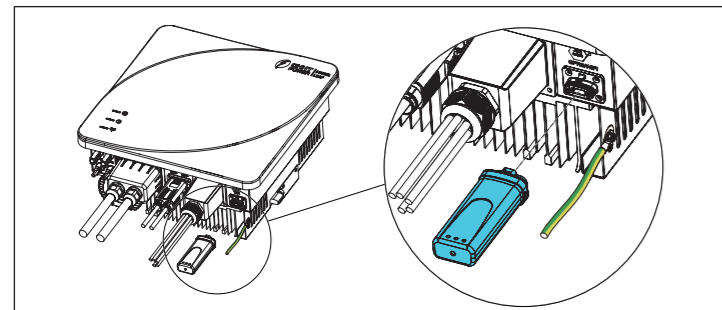

3.7 PV Cable Connection

1. Use wire stripper to remove an appropriate length of insulation layer from the DC cables as follows.

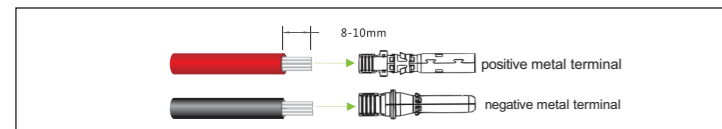

2. Insert the exposed areas of the positive and negative power cables into the metal terminals of the positive and negative connectors respectively and crimp them by crimping pliers.

3. Insert the crimped positive and negative power cables into the corresponding positive and negative connectors until a "click" sound is heard. Tighten the locking nuts of the positive and negative connectors.

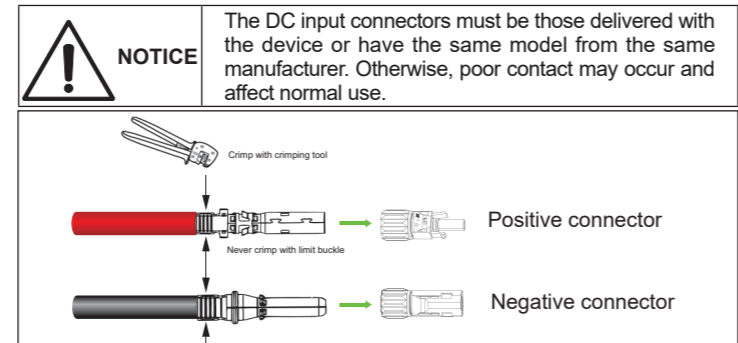

4. Measure the voltage of every route strings using a multimeter. Ensure that the polarities of the DC input power cables are correct.

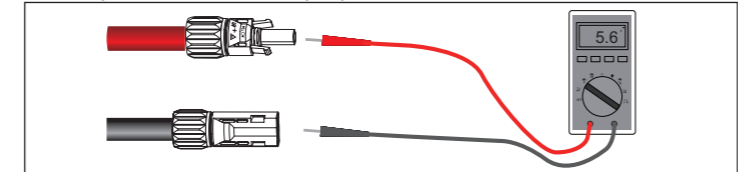

5. Insert the positive and negative connectors into their corresponding terminals of the inverter until a "click" sound is heard. Note: Use MC4 tool to remove connectors if necessary.

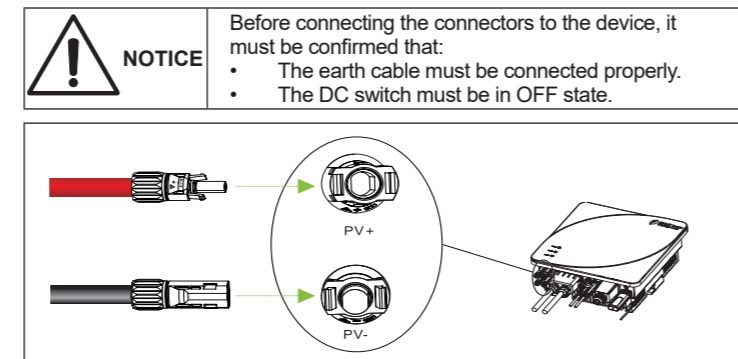

3.8 Communication Cable Connection

1. Remove the waterproof cover (1) from inverter.
2. Thread the communication line through the nut (2), clamping ring (3) and waterproof cover (1) in turn.
3. Connect the communication cables to the corresponding port, install the waterproof cover and tighten the screws (4).

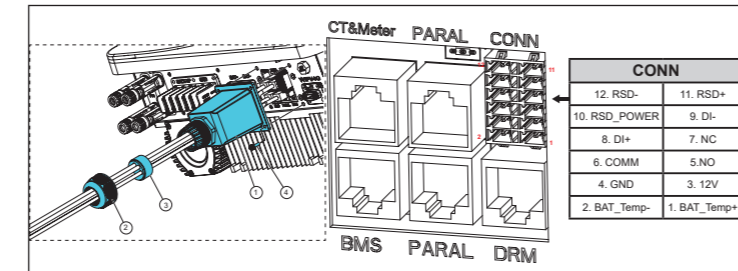

4 LED Display

Indicator	Name	Status	Description
AC output light		On (Green)	On-grid operation
		Flash (Green)	Off-grid operation
		On (Yellow)	Bypass operation
		On (Red)	No AC output
		Off	Internal communication fault
System light		On (Green)	In running
		Flash (Green)	Self inspection
		Flash (Yellow)	Module fault
		On (Yellow)	Standby
		On (Red)	Failure occurred
Communication light		Off	Internal communication fault
		On (Green)	Communication is normal
		On (Yellow)	Abnormal meter communication
		Flash (Red)	Abnormal BMS communication
		On (Red)	Internal communication fault
Off	No communication		

5 System Wiring Diagram and Commissioning

5.1 BMS/CT/Meter Cable connection

1. BMS cable: Connect RJ45 cable to inverter BMS interface and battery BMS communication interface.
2. CT cable: Connect white wire end to "I+" terminal and blue wire end to "I" terminal.
3. Meter cable: Connect RJ45 cable to inverter "CT/METER" interface and meter A & B terminals.
4. Connect L and N interface of meter to grid.

Note:
For more information on other application scenarios or cable connections, please refer to specific user manuals.

5.2 Power ON/OFF

Power ON/OFF steps are the same as follows:

1. Turn on/off On-Grid breaker;
2. Turn on/off the Back-up breaker;
3. Turn on/off the PV switch;
4. Turn on/off the BAT breaker.

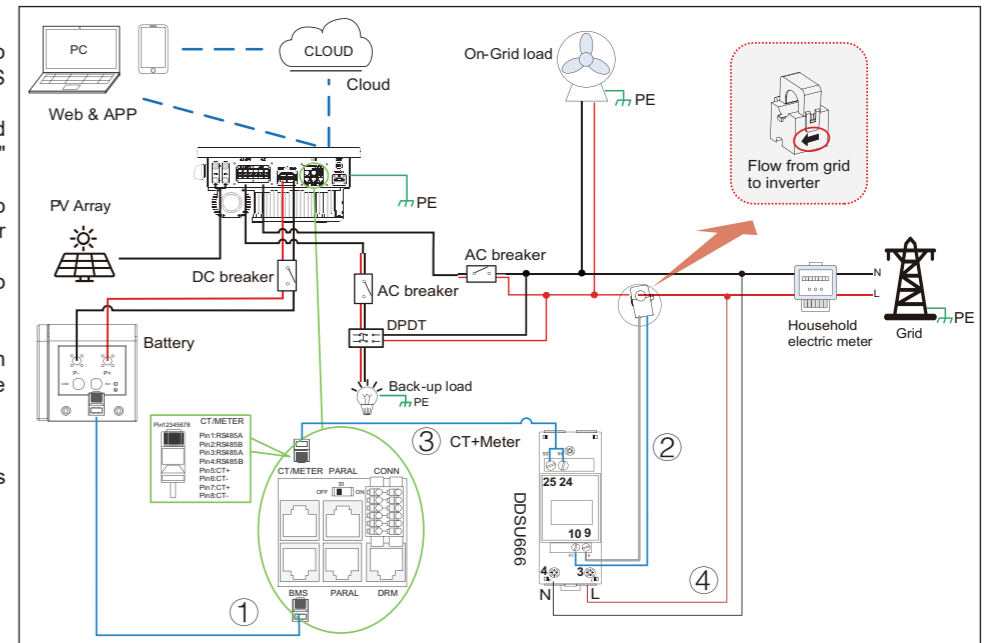

6 APP Setting

1. Set the inverter DC switch to the "ON" position. 2. Once powered, the inverter will automatically create a wireless network that can be visible as an Access Point from the user smartphone. 3. Users can download MatriCloud APP of iOS version at Apple store or Android version in Google store or scan the QR code (Support Android 4.4 and IOS 11.0 or later).
4. User can perform the following procedures to set the APP easily. First of all, open the Bluetooth function on your phone.

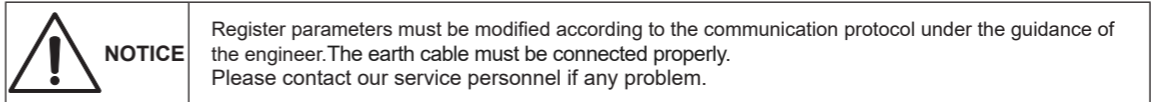

Open MatriCloud and click the "Quick installation wizard"

Click the "Bluetooth Connect".

Click device number (last 8 digits of SN on the COM rod label) to enter guide page.

Confirm all cable connections are correct. Click "Next Step".

When inverter is restarted, click "Login equipment" to enter main menu.

Click "Complete and reboot", inverter will restart automatically. If any device fault, please handle it before operating.

For Wi-Fi, click "select" to input Wi-Fi name and password, click "Next Step". If you select 4G, click "Next step" directly.

Set all the parameters following tips. Then click "Next Step".